

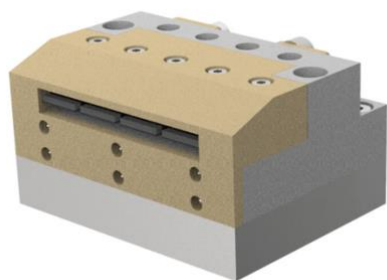

Microchannel Cooled Horizontal stack

E-stack Series



主要特性/ Features:

- ◆ 940nm wavelength
- ◆ CW 250W/Bar output power
- ◆ AuSn Packaging

应用领域/ Applications:

- ◆ Pumping
- ◆ Industrial processing
- ◆ Scientific Research

尺寸图 (mm) / Package Dimensions (mm)

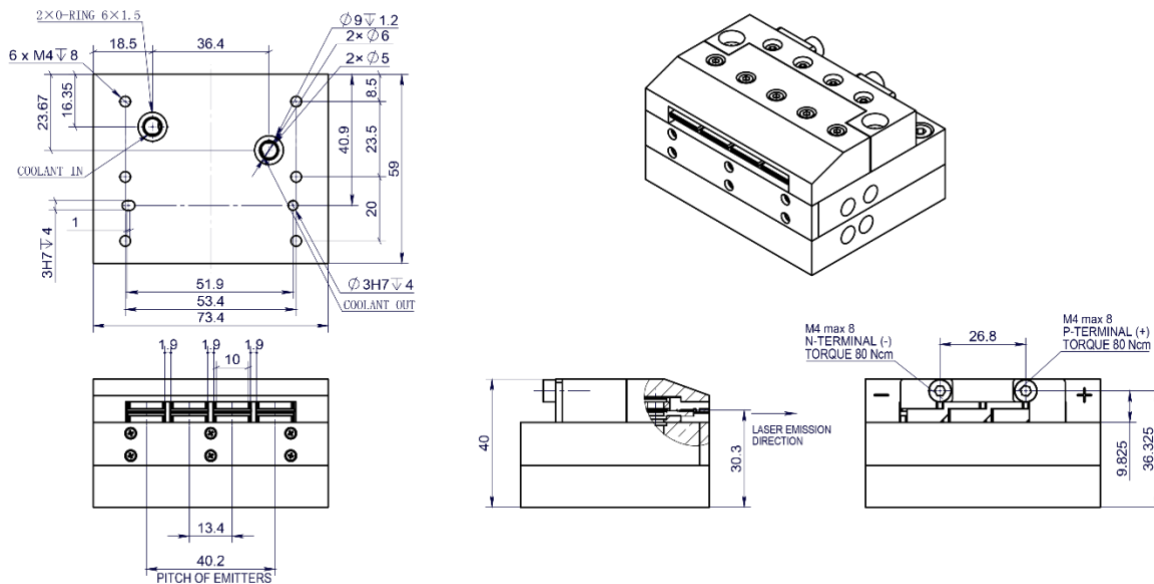

声明: 北京凯普林光电科技股份有限公司所提供的产品信息是可靠、准确的, 并有权随时对产品的设计和参数进行改进和修改, 恕不另行通知。

Declaration: information and specifications contained herein are deemed to be reliable and accurate. BWT Beijing reserves the right to change, alter or modify the design and specifications of these products at any time without notice.



Microchannel Cooled Horizontal stack

E-stack Series

规格参数(25°C) Specifications(25°C)	符号 Symbol	单位 Unit	E2Y-940D-1000C-HO1.1(4x1)		
			Minimum	Typical	Maximum
光学参数⁽¹⁾ / Optical Data⁽¹⁾					
工作模式 / Working Mode	-	-	CW		
中心波长 / Center Wavelength	λ_c	nm	940±3		
输出功率 / Output Power	P_{bol}	W	-	1000	-
光谱宽度 / Spectral Width (FWHM)	$\Delta\lambda$	nm	-	3.5	4.5
准直后快轴发散角 / FA Divergence With FAC(90%E)	θ_{\perp}	mrad	-	7	8
慢轴发散角 / SA Divergence (90%E)	$\theta_{//}$	deg	-	8	12
温度漂移 / Wavelength Shift with Temperature	$\Delta\lambda/\Delta T$	nm/°C	-	-0.31	-
电学参数⁽¹⁾ / Electrical Data⁽¹⁾					
阈值电流 / Threshold Current	I_{th}	A	-	24	28
工作电流 / Operating Current	I_{bol}	A	-	250	270
工作电压 / Operating Voltage	V_{op}	V	-	6.8	7.6
斜率效率 / Slope Efficiency	η	W/A	4	4.4	-
电光效率 / Electrical-to-Optical Efficiency	PE	%	53	58	-
其他参数 / Others					
存储温度 / Storage Temperature ⁽²⁾	T_{st}	°C	-20		55
操作温度 / Operating Temperature ⁽³⁾	T_{op}	°C	20	-	30
水压 / Pressure	P_{water}	Mpa	≤4		
水流量 / Flow Rate	Q	L/min	1.2		
去离子水质 / Cooling Water Specification	Deionized water 2.5±0.5μS/cm, pH-value 5.5-8, filter≤5μm				

(1) 数据在 25°C冷板条件下测得。Tested at 25°C cold plate temperature.

(2) 操作和储存需要非冷凝环境。A non-condensing environment is required for operation and storage.

(3) 工作温度为水冷温度，不同温度下性能可能有所不同。

The working temperature is water temperature, and the performance may vary at different temperatures.

(4) 超规格使用会导致激光器寿命减少。Reduced lifetime if used above nominal operating conditions.

(5) 其他波长及参数可根据客户需求定制。

Other wavelengths and parameters can be customized according to customer needs.

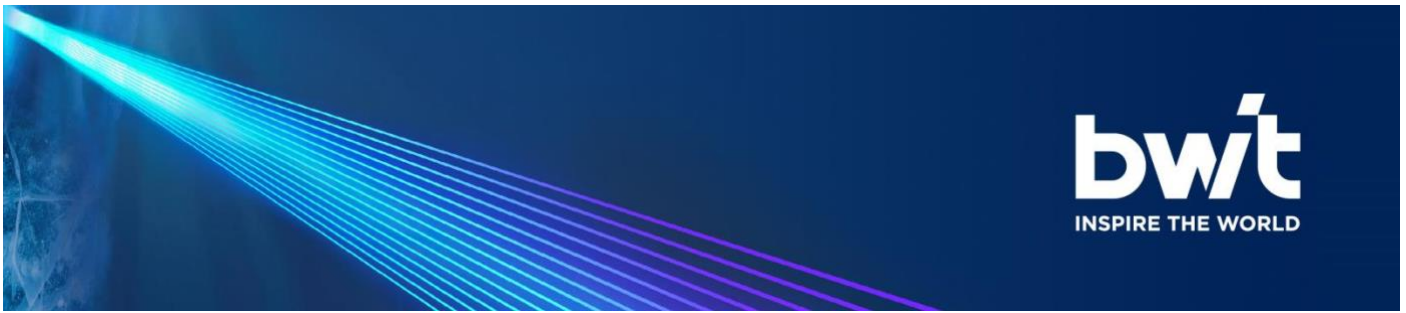

Microchannel Cooled Horizontal stack

E-stack Series

使用说明 / OPERATING NOTES

- ◆ 激光器工作时，请遵守 IEC 四级激光标准安全规范，避免激光照射眼睛和皮肤。
 - ◆ 静电击穿是导致半导体激光器失效的重要原因，激光器安装需由经过培训的人员完成，操作时需佩戴防静电手腕带，工作台需接地。在供电连接头与激光器管脚连接之前，不得移除激光器管脚上的防静电保护线。
 - ◆ 引线安装扭力 $\leq 40\text{cN.m}$
 - ◆ 电流过冲有可能导致激光器损坏，请使用稳定的恒流电源，工作时避免浪涌。
 - ◆ 应在额定电流、额定功率下使用。
 - ◆ 激光器工作时需保证良好散热。
-
- ◆ Please follow the standard safety procedures for IEC Class 4 lasers, Avoid eye and skin exposure to direct radiation during operation.
 - ◆ ESD precautions must be taken during storage, transportation and operation. Short-circuit is required between pins during storage and transportation.
 - ◆ Wire installation torque $\leq 40\text{ cN.m}$.
 - ◆ The laser may be damaged by excessive drive current, stable power supply should be used to avoid surge current.
 - ◆ The laser should be operated according to the specifications, maximum optical power should not be exceeded.
 - ◆ Laser diode must work with good cooling.



凯普林光电始创于 2003 年，公司以“让梦想驭光而行”为使命，以成为“全球激光解决方案领跑者”为愿景，以“创变非凡”为价值观，面向全球客户提供半导体、光纤、超快激光产品及解决方案。

公司追求持续创新，坚持自主可控的先进工艺和技术。为此，凯普林以北京总部为核心，先后在江苏、深圳建立了生产及研发中心，在天津投资兴建了智能化、数字化生产基地。为打造高水平技术实力和产品质量，凯普林在 2020 年成立德国子公司，为研发生产和技术创新国际化迈出坚实一步。

BWT, founded in 2003, is committed to the mission of "let the dream drive the light", the vision of becoming the "Global leader in laser solutions", and the value of "Outstanding innovation", providing diode laser, fiber laser, ultra-fast laser products and solutions to global customers.

The company pursues continuous innovation and insists on autonomous and controllable advanced process and technology. With Beijing headquarters as the core, BWT has successively established production and R&D centers in Jiangsu, and Shenzhen, and invested in the construction of an intelligent and digital production base in Tianjin. To build a high level of technical strength and product quality, BWT set up a German subsidiary in 2020, and taking a solid step for the internationalization of R&D, production and technological innovation.